

Crafter/Man 2018- Lwb Pod Fitting

Items supplied

- 1 x pair pods(either with or without window recess cut out dependant upon selection)
- 2 x longitudinal strengthening frames (handed) chamfered at rear
- 2 x upright strengthening frames (handed) tab on lower facing rear
- 1 x bonding kit (includes 2 x speedbond adhesive / 1 x plastic primer / 3 x panel wipes / 2 x scotchbrite pads / gloves)

Tools and or items needed

- Cutting tools for initial cut of vehicle panels (cutting disk / drill to ensure neat corners)
- 30 x m6 rivnuts / m6 x 25 bolts
- Masking tape / suckers and clamps for securing pods while curing
- Masking tape to ensure neat adhesive edges
- U trim if required

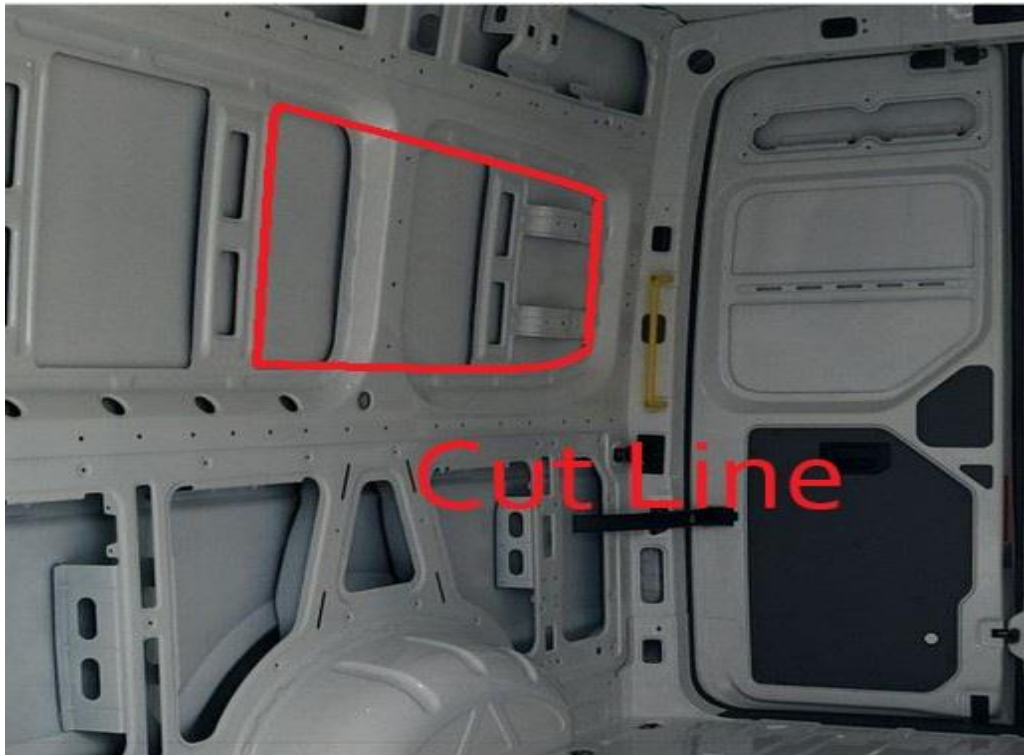

Follow Internal Skin Recess for cut line



This top section can be cut on 2 different planes dependant upon how you require it to be finished

This area then needs to be covered with steel (not supplied) ready for finishing with carpet later

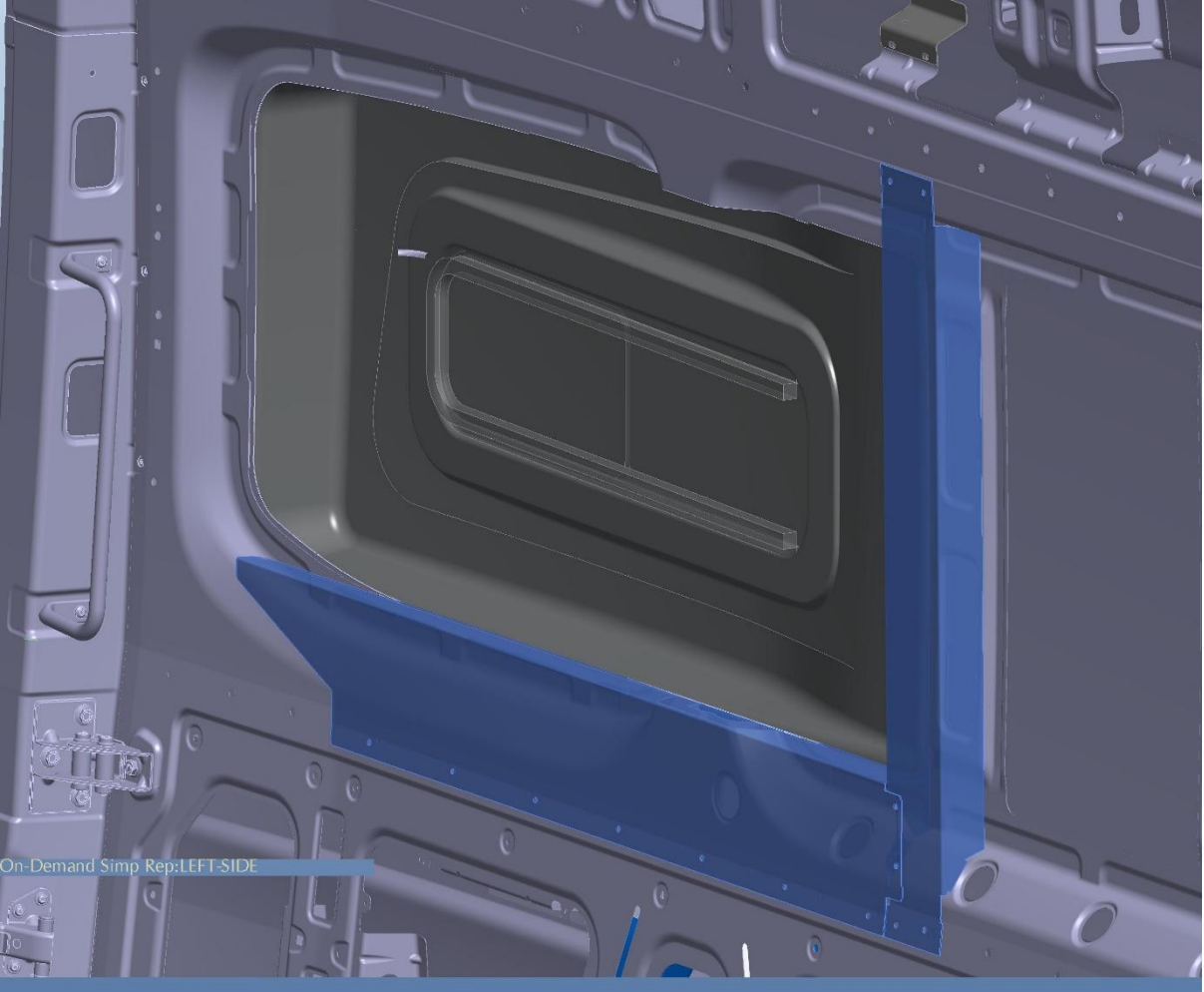

On-Demand Simp Rep:LEFT-SIDE

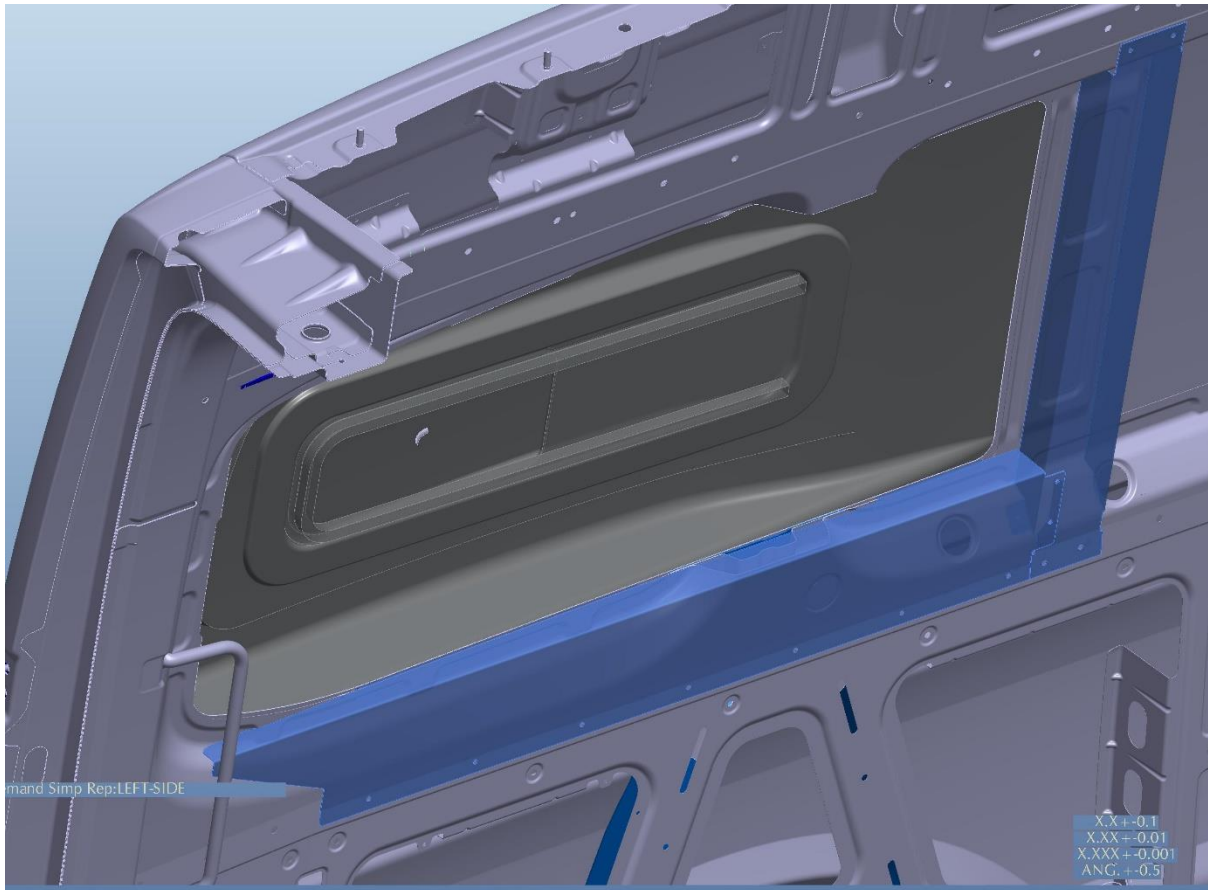

Position strengthening beams and mark holes

Remove beams and drill marks

Insert rivnuts (not supplied) into drilled holes

Treat all cut edges with primer/paint (not supplied)

If required u shaped panel trim can be installed to protect cut edges

Install strengthening beams with supplied masterseal speedbond

Consider using masking tape around edges of frames to make clean up of excess easier

Insert bolts into rivnuts and tighten (not supplied)

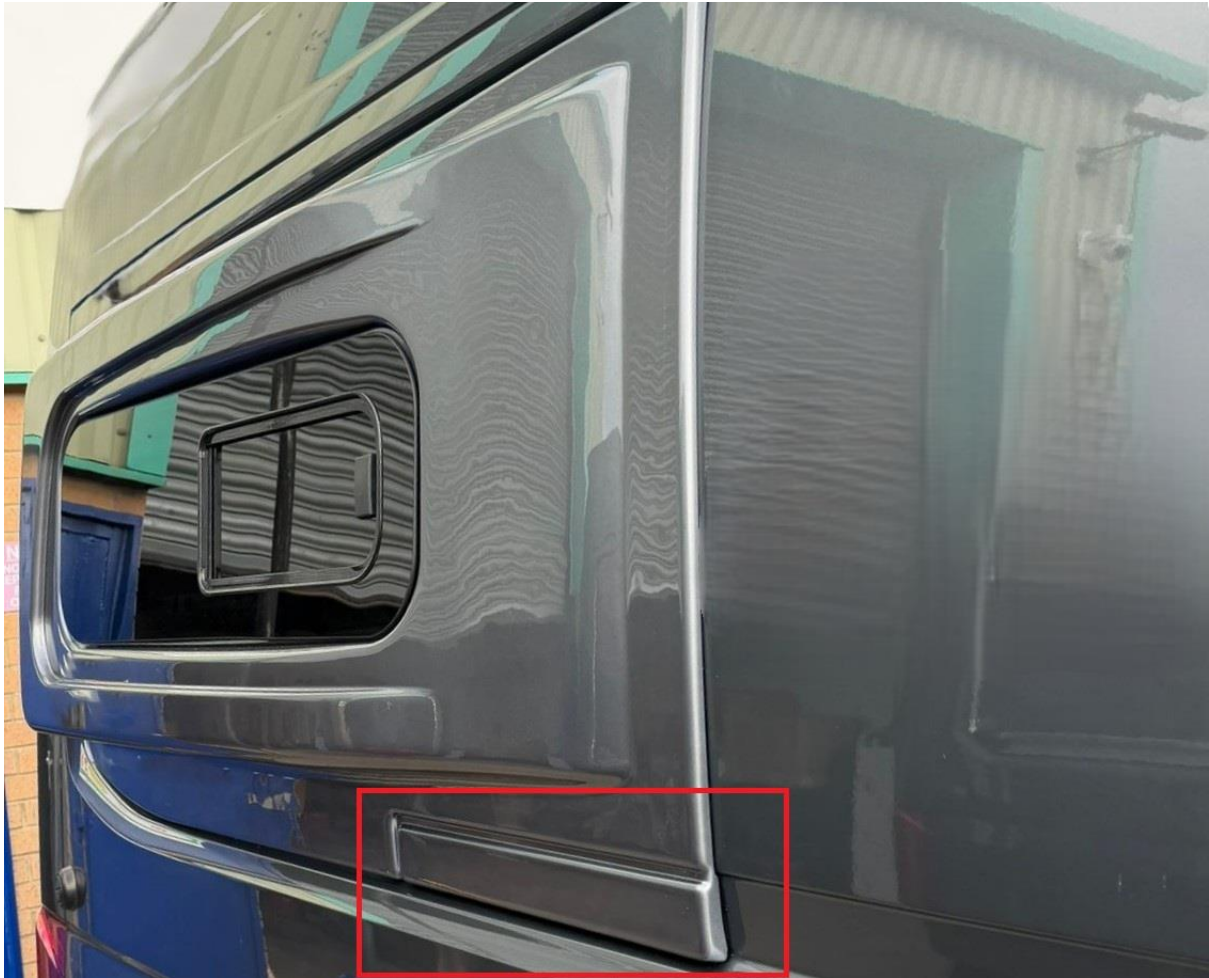

If required remove lower section on n/s pod (pictured above) if your vehicle has twin sliders to allow for track

Fit Pods to outside of vehicle, Key adhesive surface using Scotchbrite pads supplied, Apply Primer to Adhesive surfaces with supplied spray plastic primer, Use supplied Masterseal Speedbond to affix pods to side of vehicle.

Consider using masking tape around edges of sealant to make clean up of excess adhesive easier .

Clamp Or Tape pods on with Masking Tape until Cured to Ensure good seal and adhesion

Finally bond in sliding windows with Primer less Window Bond if required and finish/carpet interior as required

Also ensure that when carpeting interior of vehicle that any oe fitted slam vent's are not covered and work correctly

Please ensure when fitting work is undertaken it is in a clean and dry environment