

Crafter/Man 2018- Lwb Pod Fitting

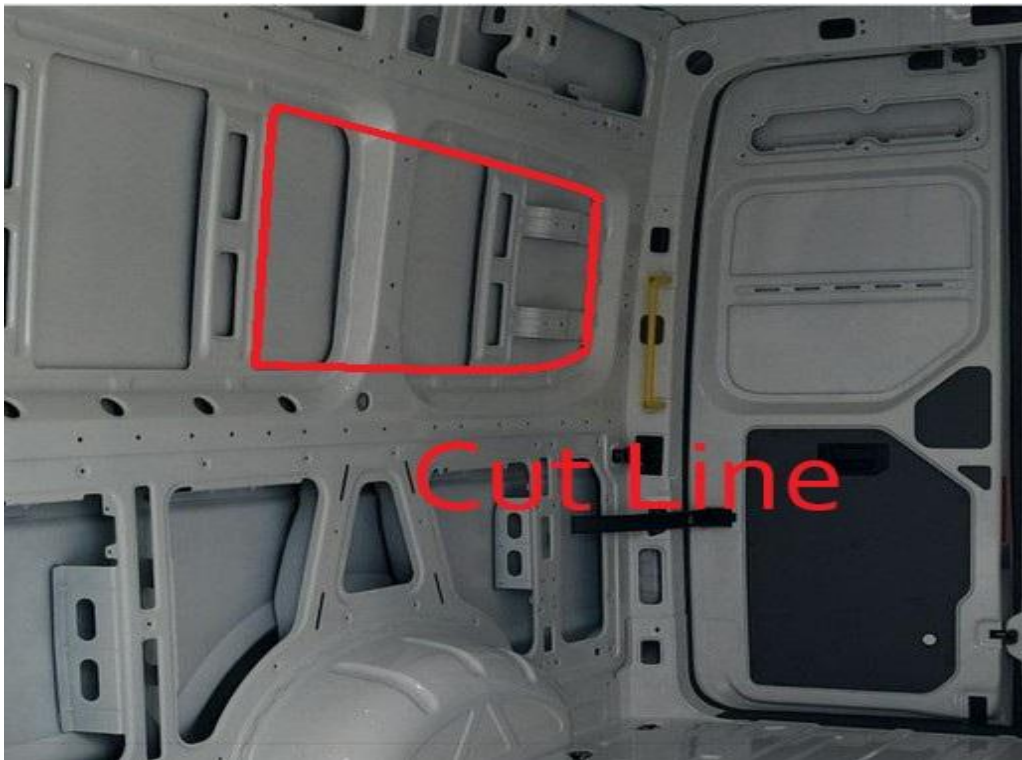

Follow Internal Skin Recess for cut line



This top section can be cut on 2 different planes dependant upon how you require it to be finished

This area then needs to be covered with steel ready for finishing with carpet later

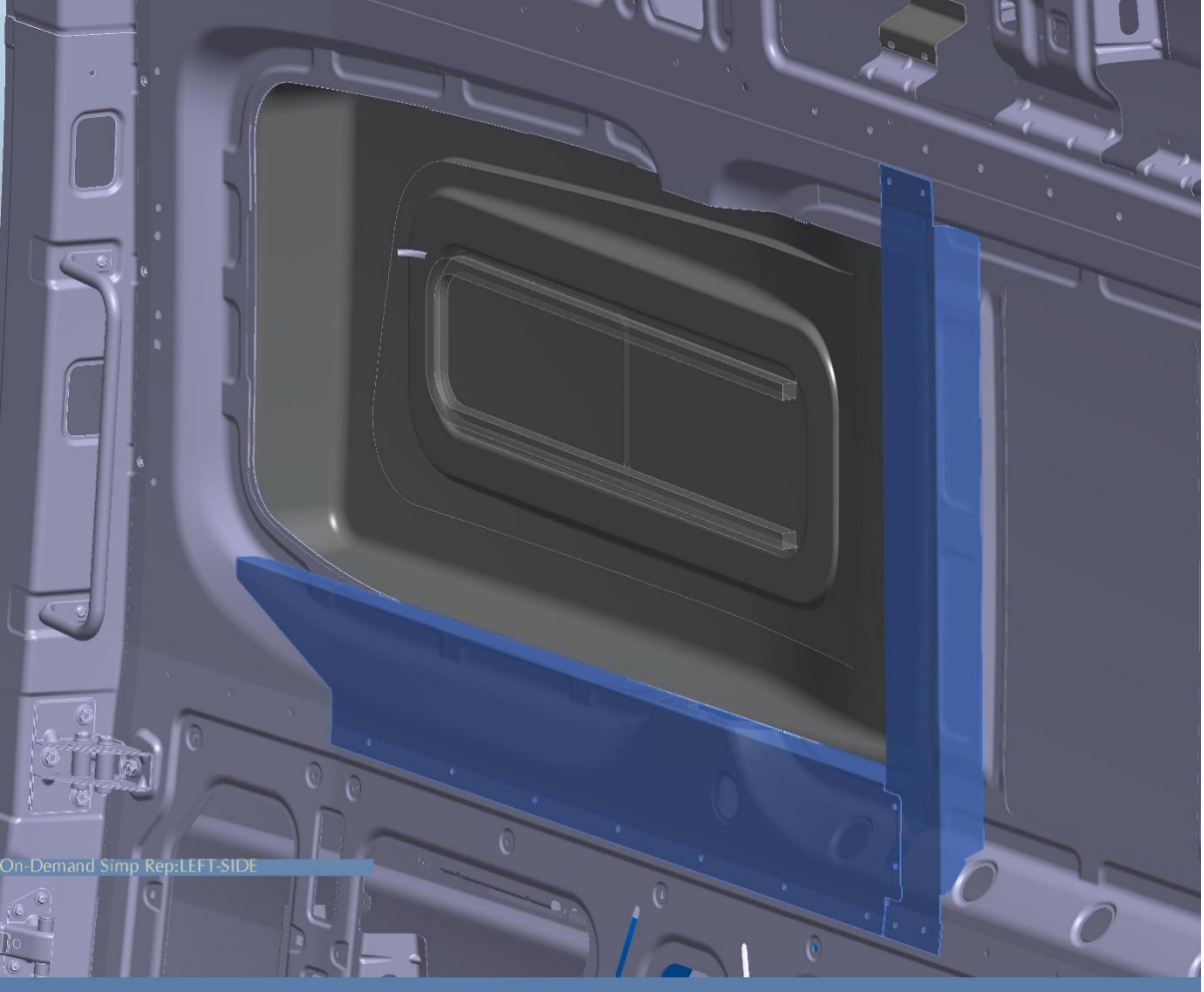

On-Demand Simp Rep:LEFT-SIDE

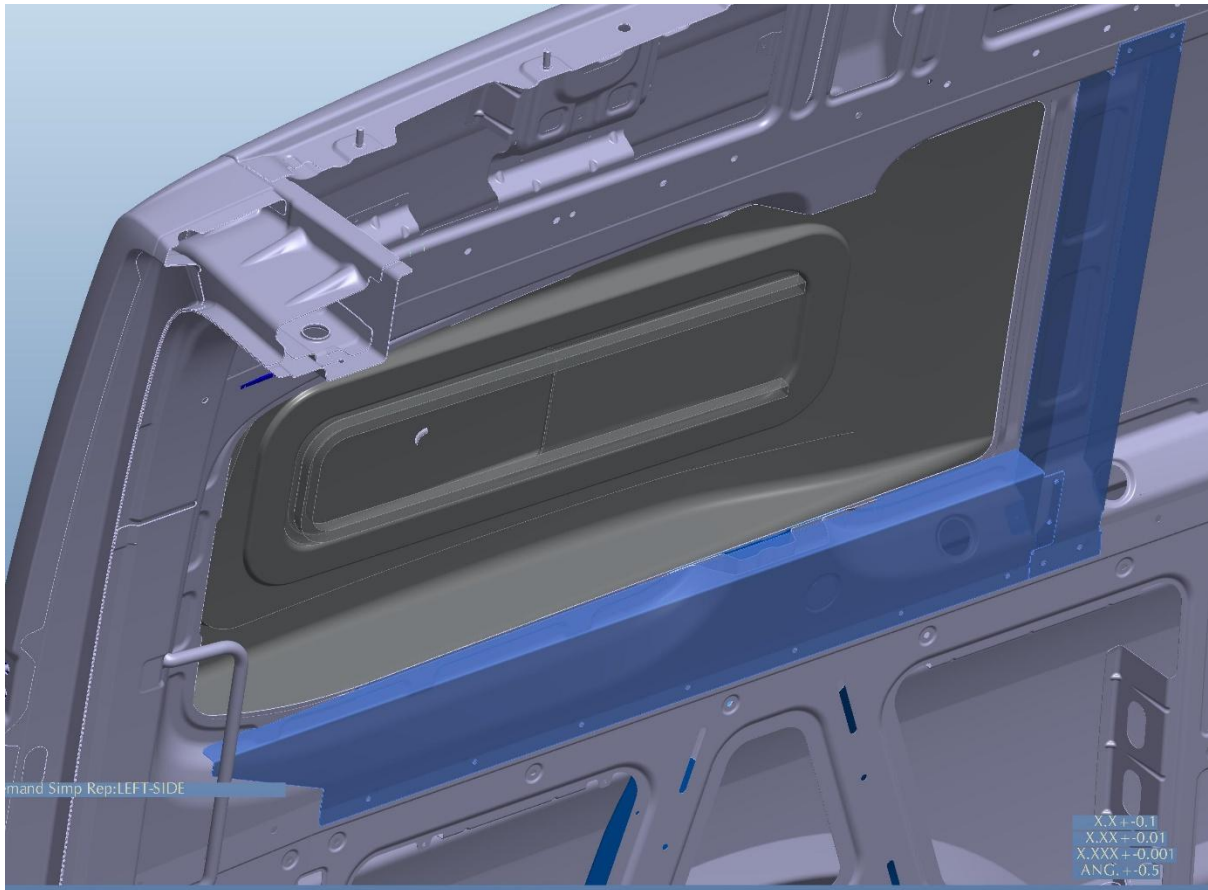

Position strengthening beams and mark holes

Remove beams and drill marks

Insert rivnuts into drilled holes

Treat all cut edges with primer/paint

Install strengthening beams with sika 522 and rivnuts

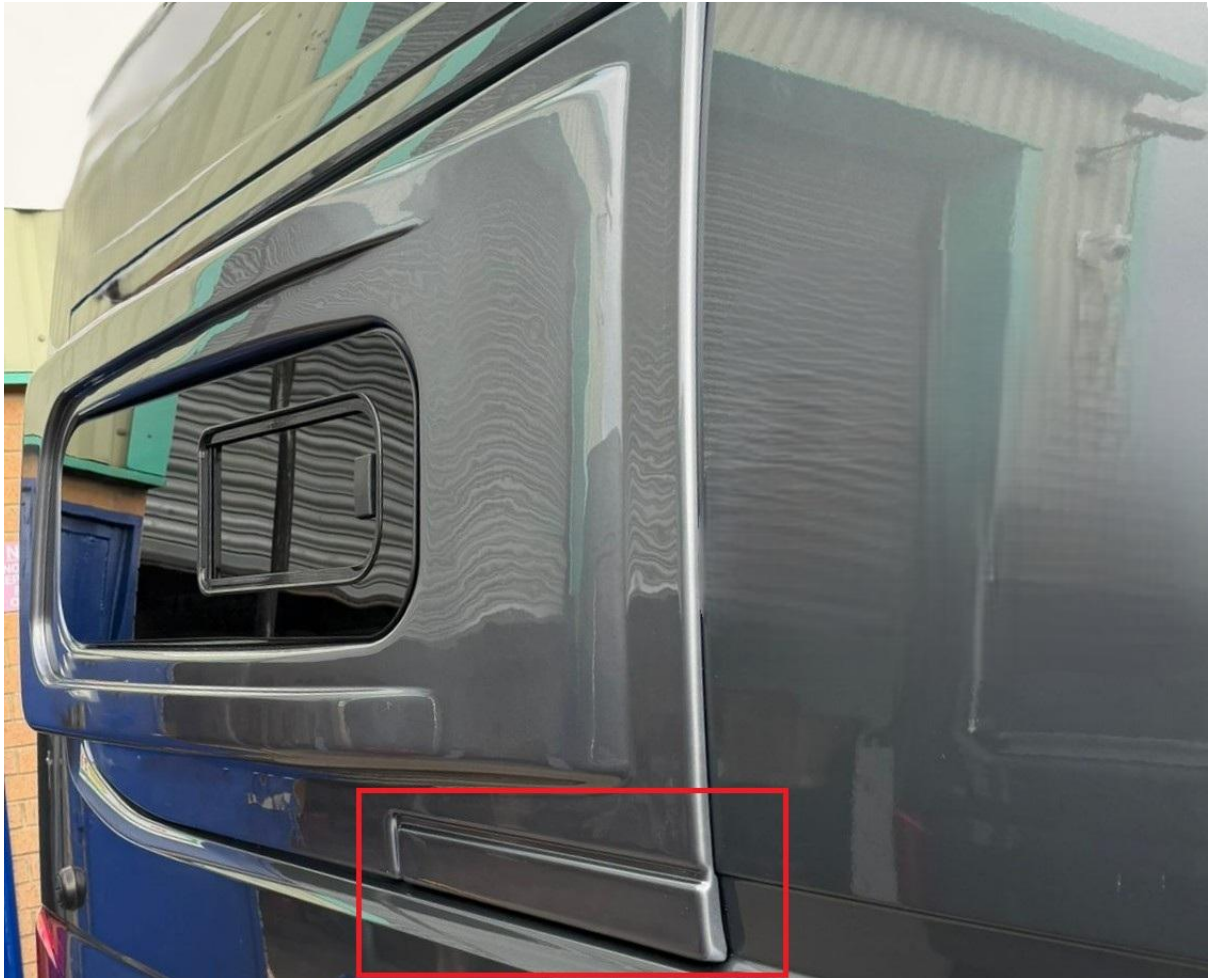

Fit Pods to outside of vehicle with either Sika or window bond

If required remove lower section on n/s pod if your vehicle has twin sliders

Finally bond in sliding windows if required and finish/carpet interior as required